

envirovent®

ENERGISAVA® 250 BASIC USER GUIDE FOR RESIDENT



Lifetime Range®

HOME VENTILATION SYSTEM GUIDE

ENERGISAVA® 250 BASIC

Whole House Heat Recovery System

What is it and why is it there?

The energiSava® 250 is a centralised heat recovery fan unit that continuously removes stale, moist air from your bathroom, kitchen, WC and replaces it with clean fresh tempered air through circular valves mounted in your ceiling and into your living room areas.

How will it help?

It will prevent the build up of moisture in the house, remove steam/condensation and odours during bathing and cooking, prevent black mould forming on the walls, behind cupboards etc. It will also help stop the dampness that you can get in your cupboards and wardrobes, on your clothes and furnishings, caused by poor ventilation. It provides continuous, all year round ideal indoor air quality.

How do I control it?

The system operates continuously 24 hours a day at a low rate known as 'trickle', to ensure your home is ventilated at the appropriate level. You can send the system into a higher rate called 'boost' by utilising the switch live. The switch live is an automatic function, sending the unit to boost when the bathroom or kitchen light is on.

Summer bypass

This helps to reduce the air temperature coming into the dwelling during the warmer periods. It is an automatic function and operates when the supply air temperature to the property is above 25°C.

Annual Running Costs

Please scan our QR code to see the annual running costs of this product.



Or visit: envirovent.com/annual-running-costs

Warranty

The EnviroVent energiSava® 250 is covered by a full 2-year warranty. You will find the terms of the warranty in the installation guide.

- **DO NOT** switch off the unit - The unit is set to run continuously 24 hours a day, 7 days a week.
- **DO NOT** adjust the ceiling valves - The valves are set to allow a certain amount of air through and should not be adjusted.

Maintenance

Recommended maintenance schedule:

The following checks are recommended to ensure that this heat recovery system operates at its optimum level.

Yearly maintenance and checks - To be carried out by the user or maintenance company.

- Check there is sufficient airflow coming through the diffusers.
- Change filters x 2 (see illustration below)
- Call EnviroVent on 01423 810 810 - Filter part code is FILTER-ES250-2

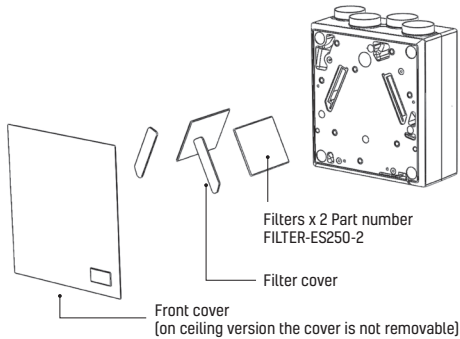

Service

The unit should be serviced every 2 years by EnviroVent, a maintenance company or other competent person. This would include filter replacements, air flow and a condense drain check. Any worn out components can then be exchanged. These would then be brought back to the Harrogate factory to be recycled.

Safety

You do not need to remove the covers from the unit, any repair work should be carried out by a qualified person to avoid hazard. If the supply cord is damaged, it must be replaced by the manufacturer, service agent or similarly qualified person.

- ⚠ **Emergency shutdown details - Unit to be isolated from the mains by turning it off at the isolating switch.**

envirovent®

Leading Manufacturer & Supplier of
Innovative & Sustainable Ventilation Systems

EnviroVent Ltd
Harrogate West Business Park
Unit 1 Bardner Bank
Killinghall
Harrogate
HG3 2SP

T / 01423 810 810
E / info@envirovent.com
W / envirovent.com



For additional information,
see the installation guide.

EN&OE | MKT ENV373 - V3 - 24.10.22

Due to our policy of continuous innovation and improvement EnviroVent reserves the right to alter products specification and appearance without notice.

We want to hear from you

Your feedback is important to us as we strive to improve our products, services, and overall customer experience. Please email us to help us serve you better: feedback@envirovent.com